

D-26-SB

Underground Air Valve System for Wastewater



Description

The D-26 SB is a complete product package that combines the reliable and efficient properties of the A.R.I. D-26 combination wastewater air valve with the added feature of a sub-surface valve that can be buried below ground. A specifically designed gear box operated horizontal sliding disc valve - situated at the base of the D-26 SB assembly - allows for the air valve disconnection and maintenance from ground level.

This shut-off valve is equipped with a safety mechanism enabling disconnection and removal of the D-26 air valve from its subsurface housing, even when the system is under pressure. Since service and maintenance operations of the unit are performed entirely from the surface, there is no need for safety considerations associated with confined space entry.

The D-26 Combination Air Valve combines an air & vacuum component and an air release component in a single body. The valve is specifically designed to operate with liquids carrying solid particles such as wastewater and effluents. The combination air valve discharges air during the filling or charging of the system, admits air into the system during drainage and at water column separation and releases accumulated air from the system while it is under pressure and operating. The valve's unique design enables the separation of the liquid from the sealing mechanism and assures optimum working conditions.

Applications

- Pump stations for sewage, wastewater & water treatment plants.
- Wastewater and effluent water transmission lines.

Operation

The air & vacuum component discharges air at high flow rates during the filling of the system and admits air into the system at high flow rates during drainage and at water column separation. Water will lift the float which activates the sealing of the valve. At any time during system operation, should internal pressure of the system fall below atmospheric pressure, air will enter the system. The intake of air in response to negative pressure protects the system from destructive vacuum conditions and prevents damage caused by water column separation. Air entry is essential to efficiently drain the system.

The air release component releases entrapped air in pressurized systems.

Without air valves, pockets of accumulated air may cause the following hydraulic disturbances:

- Restriction of effective flow due to a reduction of the flow area. In extreme cases this will cause complete flow stoppage.
- Obstruction of efficient hydraulic transmission due to air flow disturbances.
- Acceleration of cavitation damages.
- Increase in pressure transients and surges.
- Internal corrosion of pipes, fittings and accessories.
- Dangerous high-energy bursts of compressed air.
- Inaccuracies in flow metering.

As the system fills and is pressurized, the combination wastewater air valve functions in the following stages:

1. Air is discharged by the valve.
2. When the liquid level reaches the valve's lower portion, the float is lifted, pushing the sealing mechanism to its sealing position.
3. The entrapped air is confined in a pocket between the level of the liquid and the sealing mechanism.
4. Increases in system pressure compress the trapped air in the upper section of the conical chamber. The conical shape assures the height of the air gap. This enables separation of the liquid from the sealing mechanism.
5. Entrapped air, accumulating at peaks and along the system, rises to the top of the valve and displaces the liquid in the valve's body.
6. When the liquid level lowers to a point where the float is no longer buoyant, the float drops, unsealing the air release seal. The air release orifice opens and allows part of the air that accumulated in the upper portion of the valve to be released to the atmosphere.
7. Liquid enters the valve. The float rises, pushing the air release seal to its sealing position. The remaining air gap prevents the wastewater from fouling the mechanism.

When internal pressure falls below atmospheric pressure (negative pressure):

1. The float will drop down, immediately opening the air & vacuum and air release orifices.
2. Air will enter into the system.

Main Features

D-26 SB Underground Air Valve System for Wastewater:

- The D-26 SB incorporates an integral, flat, gear box operated horizontal sliding disc valve with a 3" full bore passage.
- The shut-off valve is operated from the surface.
- Easy and efficient back flushing can be achieved while the air valve is in its sub-surface housing.
- All connections utilize quick connectors to facilitate easy usage during:
 1. Handling (quick connector from adaptor to shut-off valve)
 2. Maintenance operations (quick connectors on both the inlet & outlet flushing positions).
- Safety elements: Disengaging the air valve is safeguarded: unless the shut-off valve is in the "closed" position and the internal pressure is released, it is not possible to extract the air valve.
- Pipe connections: 3" threaded (BSP/NPT) or flanged, in accordance with all standards.
- All parts are corrosion resistant: Metal parts made of Stainless Steel, Ductile Iron or steel, Composite material parts made of Nylon, PA, and PVC

D-26 Combination Wastewater Air Valve

- Working pressure range:
 - 2" - 0.1 - 16 bar
 - 3" - 0.2 - 16 bar, 0.2 - 25 bar
- Testing pressure: 1.5 times the max. working pressure.
- Maximum working temperature: 60° C.
- Maximum intermittent temperature: 90° C.
- A combination air valve for wastewater, with a large air & vacuum orifice and a small air release orifice integrated into one body.
- The unique design of the valve prevents contact between the wastewater and the sealing mechanism by creating an air gap at the top of the valve. These features are achieved by:
 1. **The conical body shape and the external lever:** designed to maintain the maximum distance between the liquid and the sealing mechanism and still obtain minimum body length.
 2. **Spring-guided linkage between the float/rod assembly and the sealing mechanism:** allows free movement of the float and rod. Vibrations and movement of the float due to turbulence will not unseat the sealing mechanism.
 3. **Funnel-shaped lower body:** designed to ensure that residue wastewater matter will fall back into the system and be carried away by the main pipe.
 4. **Spray Guard®:** minimizes liquid spray discharge from the air valve outlet, mainly during rapid pipeline filling conditions.
- All inner metal parts made of stainless steel.
- Unique design of external lever prevents contact between the wastewater and the sealing mechanism, prevents clogging by floating solids and ensures drip-tight sealing.
- The D-26's orifice plug-disc linkage assembly is external, keeping the levers and pins outside the air valve body and its corrosive atmosphere.

Advantages and Benefits

- Relatively lightweight and convenient to install.
- Sub-surface installation.
- Low installation costs:
 1. No need for expensive, large excavation.
 2. No need for expensive, human-accessible manholes.
- Low maintenance costs:
 1. No need for specialized tools or safety equipment.
 2. One person for operation and maintenance.
 3. Clean and environmentally friendly.
 4. Complete service and maintenance system, including an integral disassembly mechanism to ensure easy back flushing and servicing, while reducing the need for spare changeable valves.
- Safe in operation:
 1. Greatly reduces the danger of contact with local fauna – snakes and scorpions, etc!
 2. Operated and maintained entirely from ground level.
- Reliable and efficient operation:
 1. Dynamic design allows high capacity air discharge while preventing premature closure.
 2. Proven Rolling Seal mechanism.
 3. Since the valve is a sub-surface (underground), it is more resistant to frost conditions.

Valve Selection

- Available in 2", 3".
- Two different installation lengths:
 1. 800 mm tube; complete system length: 1010 mm.
 2. 1000 mm tube; complete system length: 1210 mm.
- Standard cast ductile (2" reinforced nylon body), also available with a stainless steel body and polyethylene cover.
- Valve body coating: fusion bonded epoxy coating in compliance with the standard DIN 30677-2.
- Other coatings are available upon request.

Note

- The D-26 SB air valve is intended for use with raw wastewater. For use with aggressive liquids, please consult with our application engineers or with the marketing dept.
- For best suitability, it is recommended to send the fluid chemical properties along with the valve request.
- Upon ordering, please specify: model, size, length, working pressure, thread and flange standard and type of liquid.

Sample Installation Scheme

Important Information: Prior to site preparation and installation, please refer to the D-26 SB Installation and Maintenance Manual for all the relevant instructions and information. The manual can be obtained by contacting the A.R.I. marketing dept., from your local A.R.I. distributor or downloading the file from our website.

DIMENSIONS AND WEIGHTS

Model	DN	Dimensions (mm)				Weight Kg.		Orifice Area mm ²	
		A	B	C	D	RN	ST	A / V	Auto.
L800	2"	500	971	875	806	39.5	47.9	1963	8.6
L1000	2"	500	1170	1075	1006	41.0	57.1	1963	8.6
L800	3"	500	1010	875	806	-	53.5	5024	15.7
L1000	3"	500	1210	1075	1006	-	57.3	5024	15.7

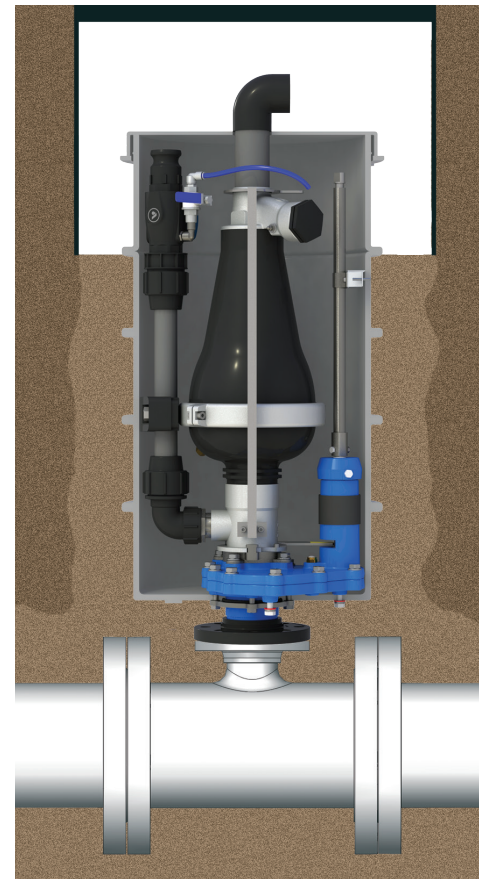

UNDERGROUND AIR VALVE SYSTEM PARTS LIST AND SPECIFICATION

No	Part	Material
1.	Discharge Outlet	PVC
2.	Valve Box Cover	Polyethylene
3.	Pressure Relief Valve	Stainless Steel SAE 316
4.	Ball Valve 1 1/2"	Stainless Steel SAE 316
5.	Lifting Handle	Stainless Steel SAE 316
6.	Back Flushing Assembly	Polyethylene
7.	Operating Rod	Stainless Steel SAE 316
8.	D-26 Air Valve	see below
9.	Sliding Disc Valve w/ Gear Box	DI+STST+EPDM /STST+STST+EPDM
10.	Adaptor - Quick Connector 3"	Stainless Steel SAE 316
11.	Safety Plate	Stainless Steel SAE 316
12.	"T" Key	Stainless Steel SAE 316
13.	Valve Box	Polyethylene
14.	Flange 3" / 4"	Reinforced Nylon /Stainless Steel SAE 316

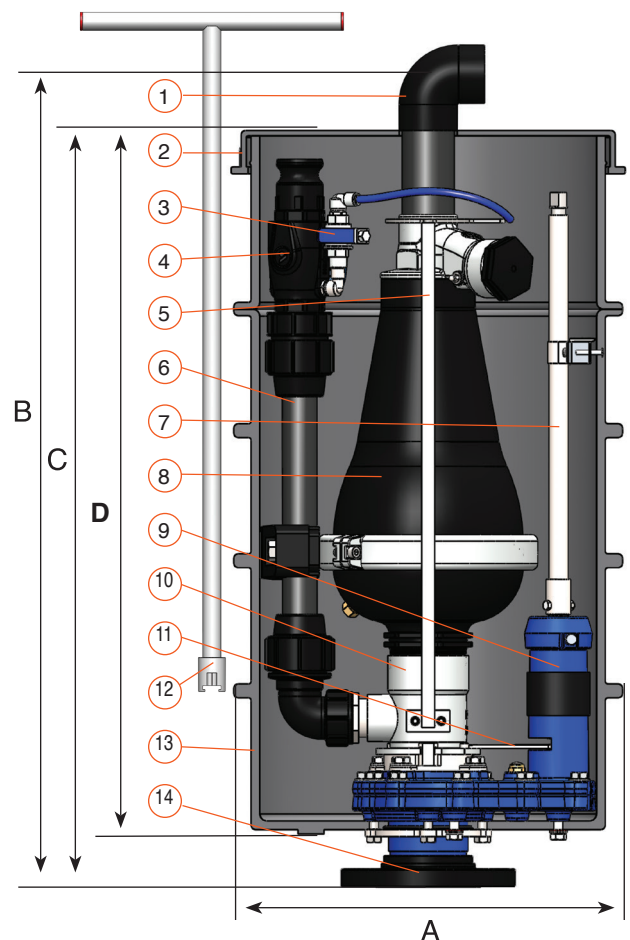

D-26 2"

AIR & VACUUM FLOW RATE

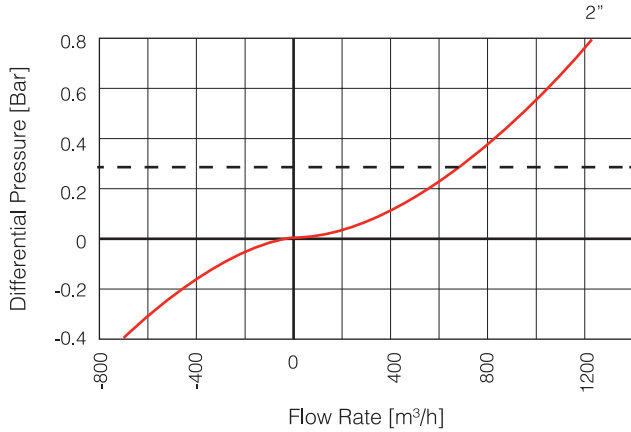

AUTOMATIC AIR RELEASE FLOW RATE

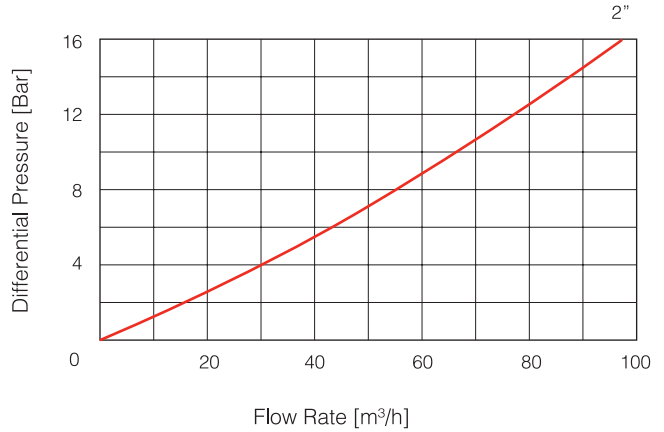

D-26 2" PARTS LIST AND SPECIFICATION

No.	Part	Material
1.	Threaded Plug	Polypropylene
2.	Cover	Stainless Steel SAE 316
3.	Disk Arm Assy.	Cast ST ST
4.	O-ring	BUNA-N
5.	Air & Vacuum Seal	EPDM
6.	Air Release Seal	EPDM
7.	Spring	Stainless Steel SAE 316
8.	Spray Guard*	Polypropylene
9.	Body	Reinforced Nylon / Stainless Steel SAE 316
10.	Float	Polypropylene
11.	Clamp	Cast Stainless Steel
12.	O-ring	BUNA-N
13.	Tap	Brass / Stainless Steel
14.	Base	Reinforced Nylon / Stainless Steel SAE 316

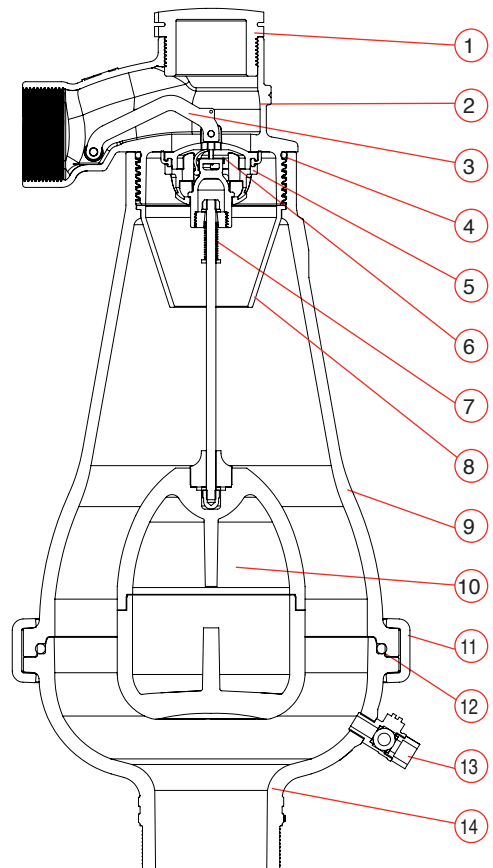

D-26 3"

AIR & VACUUM FLOW RATE

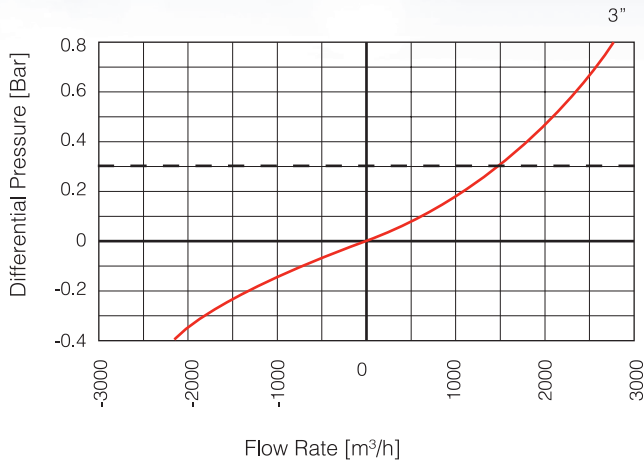

AUTOMATIC AIR RELEASE FLOW RATE

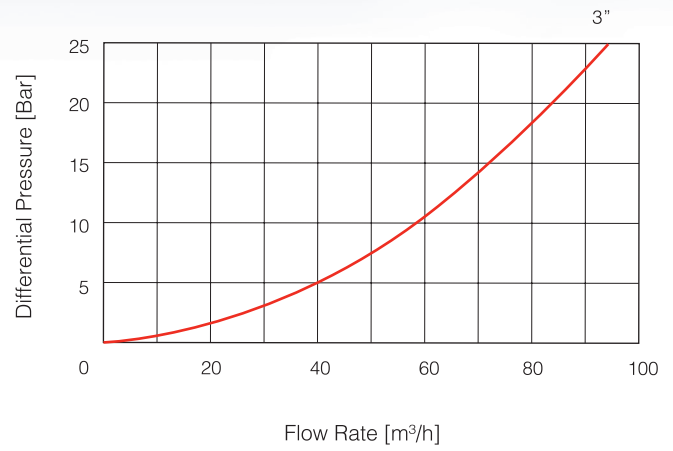

--- Max. recommended design air discharge

D-26 3" PARTS LIST AND SPECIFICATION

No.	Part	Material
1.	Cover	Cast Stainless Steel
2.	Disk Arm Assembly	Cast Stainless Steel + Rubber
3.	Air & Vacuum Disc	Cast Stainless Steel / Reinforced Nylon
4.	Air & Vacuum Disc Seal	E.P.D.M.
5.	Air Release Disc Seal	E.P.D.M.
6.	Air Release Disc	Reinforced Nylon
7.	Stopper	Polypropylene
8.	Washer	Stainless Steel 304
9.	Float Assy.	Stainless Steel 316 / Polycarbonate + Stainless Steel 316
10.	Plug	Stainless Steel 304
11.	Plug	PVC
12.	Rivet	Stainless Steel 304
13.	O-Ring	BUNA-N
14.	Bolt	Stainless Steel 316
15.	Spray Guard®	Polypropylene
16.	Air Release Disc Cover	Reinforced Nylon
17.	Domed Nut	Stainless Steel 304
18.	Rod Adaptor	Polypropylene
19.	Spring	Stainless Steel 316
20.	Body	Stainless Steel 316 / Carbon Steel

